

MB Series Motor Brake

MB-1000 Flange Mounted Normal Duty

Model	Function	Mounting
MB-1000	Motor Brake	Normal Duty

NEMA Frame Size	Dim. D
284C & 286C or TC	7



Application

A motor brake mounts directly on the end bell of a double shafted motor.

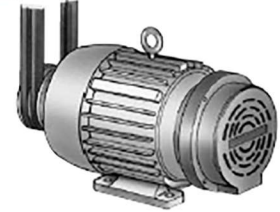
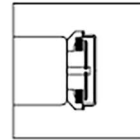

Drawing I-25591

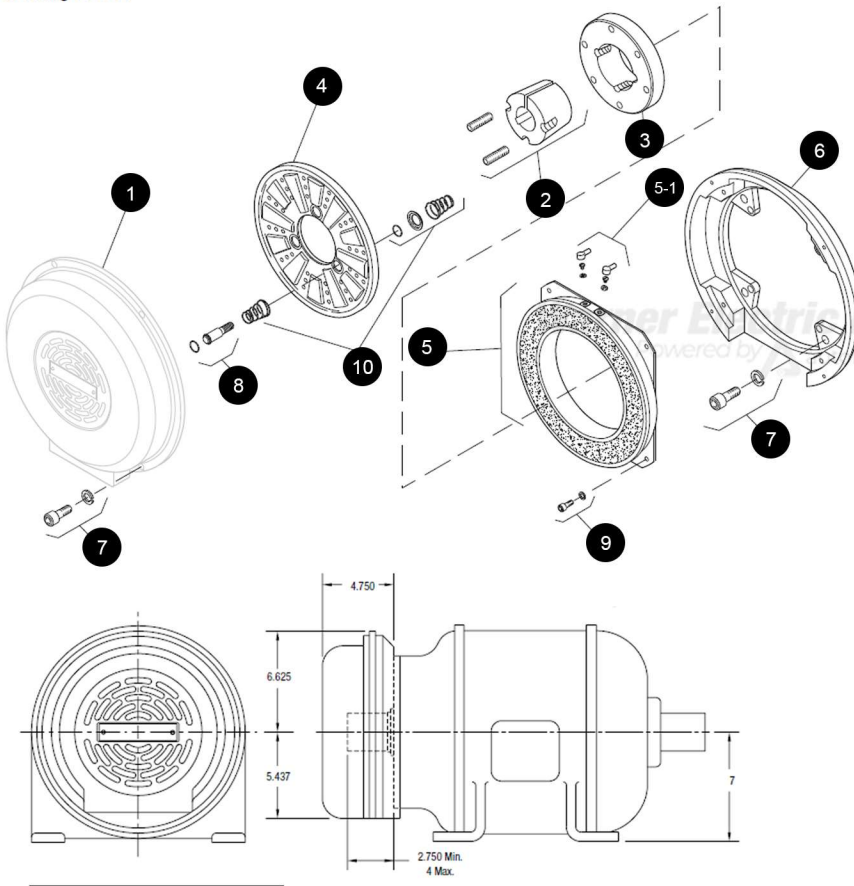

Item	Description	Part Number	Qty.
1	Cover	5352-288-001	N/A
2	Bushing*		1
	1/2" to 2-1/2" Bore	180-0185 to 180-0217	
3	Armature Hub	540-0313	1
4	Armature	5302-111-013	1
5	Magnet - 90 Volt	5352-631-001	1
5-1	Terminal Accessory	5311-101-001	1
6	Adapter	5352-105-001	1
7	Mounting Accessory	5351-101-003	1
8	Drive Pin and Retainer	5301-101-001	3
9	Mounting Accessory	5321-101-002	2
10	Spring Accessory	5301-101-014	1

Bushing Part Numbers

Shaft Size	Keyway Size	Bushing Number		Shaft Size	Keyway Size	Bushing Number	
		Warner Electric	Warner Electric			Warner Electric	Warner Electric
1/2	1/8 x 1/16	180-0185		1 1/2	3/8 x 3/16	180-0201	
9/16	1/8 x 1/16	180-0186		1 9/16	3/8 x 3/16	180-0202	
5/8	3/16 x 3/32	180-0187		1 5/8	3/8 x 3/16	180-0203	
11/16	3/16 x 3/32	180-0188		1 11/16	3/8 x 3/16	180-0204	
3/4	3/16 x 3/32	180-0189		1 3/4	3/8 x 3/16	180-0205	
13/16	3/16 x 3/32	180-0190		1 13/16	1/2 x 1/4	180-0206	
7/8	3/16 x 3/32	180-0191		1 7/8	1/2 x 1/4	180-0207	
15/16	1/4 x 1/8	180-0192		1 15/16	1/2 x 1/4	180-0208	
1	1/4 x 1/8	180-0193		2	1/2 x 1/4	180-0209	
1 1/16	1/4 x 1/8	180-0194		2 1/16	1/2 x 1/4	180-0210	
1 1/8	1/4 x 1/8	180-0195		2 1/8	1/2 x 1/4	180-0211	
1 3/16	1/4 x 1/8	180-0196		2 3/16	1/2 x 1/4	180-0212	
1 1/4	1/4 x 1/8	180-0197		2 1/4	1/2 x 1/4	180-0213	
1 5/16	5/16 x 5/32	180-0198		2 5/16	5/8 x 5/16	180-0214	
1 3/8	5/16 x 5/32	180-0199		2 3/8	5/8 x 5/16	180-0215	
1 7/16	3/8 x 3/16	180-0200		2 7/16	5/8 x 5/16	180-0216	
				2 1/2	5/8 x 5/16	180-0217	

Coil Data

Unit Size	PB & MB-1000		
Voltage — DC	6	24	90
Resistance @ 20°C — Ohms	1.23	19.7	248.7
Current — Amperes	4.87	1.22	.36
Watts	29	29	33
Coil Build-up — Milliseconds	205	220	235
Coil Decay — Milliseconds	70	75	80

Weights and Inertia

Unit Size	MB-1000	
	Wt. (lbs.)	Inertia (lbs.ft. ²)
Magnet.....	10.549
Armature & Pins.....	6.0	.629
Armature Hub.....	3.860	.164
Bushing: Max. Bore to	1.533	.022
Min. Bore.....	3.575	.031
Cover.....	4.875
Adapter.....	5.5

All pictures shown are for illustration purposes only, Please refer to Catalog / Users Manual for more information.