

# UM-C Series UniModule – Ceramic Faced

## High Performance with Extended Life

UniModules with ceramic friction material are pre-burnished during manufacturing to provide rated torque performance upon start up. They have been designed to mate easily with industry standard motors, reducers and other power transmission components.

- Bolt-it-down, wire-it-up... it's ready to go
- Available in 3 sizes; 50, 180 and 210 and 2 configurations; 1020 and 2030
- Standard voltages available 6V, 24V and 90V DC
- C-face or foot mounted
- No maintenance required
- Accurate positioning when used with CBC-700 OEX control

### The Ceramic Difference . . .

#### Extended Life for High Cycle Rate Use

Ceramic faced clutches and brakes have been designed specifically for rapid cycling applications to satisfy today's needs for high speed equipment. Ceramic friction material provides excellent wear resistance that extends life 3 to 5 times that of standard clutch/brakes in demanding applications.

#### Consistent Torque and Cycle Repeatability

Preloaded armatures keep the ceramic friction surfaces lightly in contact to provide consistent torque and cycle-to-cycle repeatability. Variation is reduced by up to 30% over standard units. Autogap™ is not required.

#### Controllability and Accuracy – Smooth Start/Stop

With the ceramic friction surfaces always in contact, dynamic torque response is fast and precise. When used with a CBC-700 over-excitation control or CBC-300, exceptional clutch/brake performance can be achieved approaching that of more expensive motion control technologies—The PerformancePlus difference!  
Controls - see page CTL-18.



Sizes 50 & 180

Size 210



### UM-C Product Life

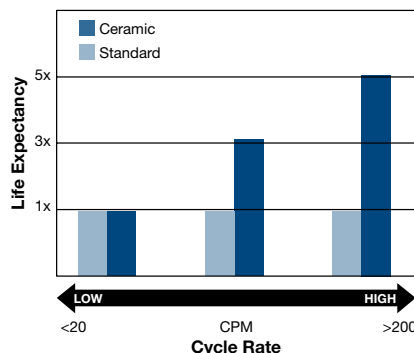

### UM-C Cycle Repeat

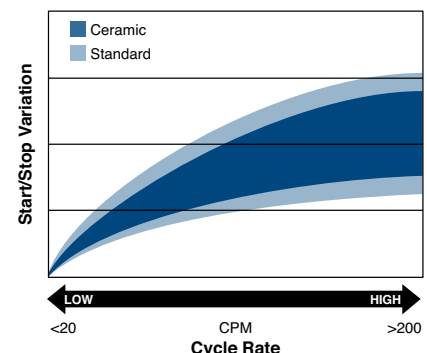

# UM-C Series UniModule – Ceramic Faced

## Selection

Ceramic UniModule clutch/brake units may be mounted directly to NEMA C-face motors and reducers, or can be base mounted.

### 1. Determine Mounting Configuration

#### a. NEMA C-face Mounting (1020 Configuration)

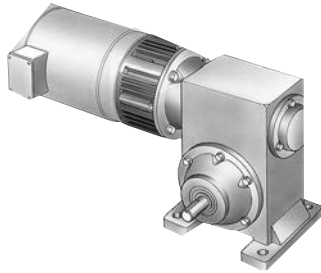

To select the correct Ceramic UniModule package, determine the NEMA frame size of your motor and/or reducer, and choose the corresponding size UniModule from the Frame Size Selection chart.

#### b. Base Mount (2030 Configuration)

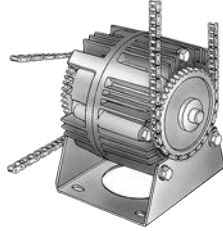

Ceramic UniModule assemblies may be mounted as separate drive units driven from the prime mover by V-belts, chain and sprockets, couplings, timing belts and other standard power transmission components.

Select the correct size module from the Horsepower vs. Shaft Speed chart by determining the motor horsepower and RPM at the module location. The correct size UniModule is shown at the intersection of the HP and operating speed. For additional sizing information, refer to the technical sizing procedure (step 2).

### 2. Determine Technical Requirements

Technical considerations for sizing and selection are torque and heat dissipation. Each merits careful consideration, especially heat dissipation as over time, use in excessive temperature environments will have an adverse effect on bearing life and coil wire insulation integrity.

Compare the calculated torque requirement with the average dynamic torque ratings. Select a unit with adequate torque. If the unit selected on torque is different than the unit selected based on heat, select the larger size unit.

### Frame Size Selection

NEMA Frame Size	UniModule Size
56C/48Y	UM-50-C
182C/143TC 184C/145TC	UM-180-C
213C/182TC 215C/184TC	UM-210-C

### Horsepower vs. Shaft Speed

HP	SHAFT SPEED AT CLUTCH (IN RPM)																		
	100	200	300	400	500	600	700	800	900	1000	1100	1200	1500	1800	2000	2400	3000	3600	
1/4																			
1/2																			
3/4																			
1																			
1-1/2																			
2																			
3																			
5																			
7-1/2																			
10																			

\*For applications with speeds below 100RPM, please contact Warner Electric Application Support.

# UM-C Series UniModule – Ceramic Faced

## a. Heat Dissipation Sizing

Friction surfaces slip during the initial period of engagement and, as a result, heat is generated. The clutch/brake selected must have a heat dissipation rating greater than the heat generated by the application. Therefore, in high inertia or high cycle rate applications, it is necessary to check the heat dissipation carefully. Inertia, speed and cycle rate are the required parameters.

Heat dissipation requirement is calculated as follows:

$$E = 1.7 \times WR^2 \times (N/100)^2 \times F$$

where:

$$E = \text{Heat (lb. ft./min.)}$$

$WR^2$  = Total reflected inertia at the clutch/brake shaft. Include the clutch/brake output inertia. (lb.ft.<sup>2</sup>)

N = Speed in revolutions per minute (RPM)

F = Cycle rate in cycles per minute (CPM)

Compare the calculated heat generated in the application to the unit ratings using the heat dissipation curves. Select the appropriate unit that has adequate heat dissipation ability.

Note: At low cycle rates, the ceramic designs provide no additional wear life than standard designs.

## Heat Dissipation Curves

### UM 50-C

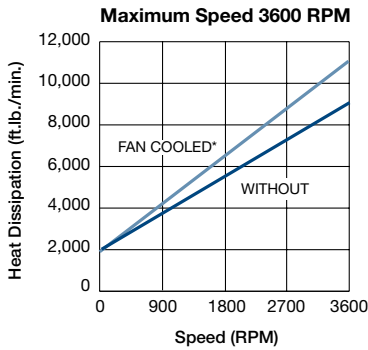

### UM 180-C

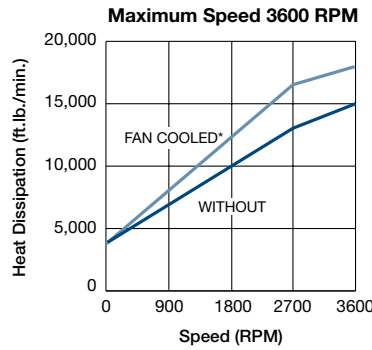

### UM 210-C

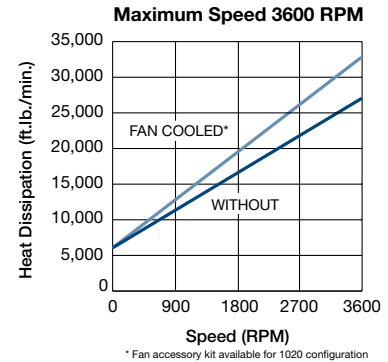

## b. Torque Sizing

For most applications, the correct size clutch/brake can be selected from the Horsepower vs. Shaft Speed chart.

Determine the motor horsepower and the RPM at the clutch/brake. The correct size unit is shown at the intersection of horsepower and shaft speed.

If the static torque requirements are known, refer to the Specifications Table to select a unit.

For some applications, the torque requirement is determined by the time allowed to accelerate and decelerate the load. (This time is generally specified in milliseconds.) For these applications, it is necessary to determine the torque requirement based on load inertia and the time allowed for engagement.

The torque requirements are calculated as follows:

$$T = (WR^2 \times N) / (308 \times t)$$

where:

$$T = \text{Average Dynamic Torque (lb. ft.)}$$

$WR^2$  = Total reflected inertia at the clutch/brake shaft. Include the clutch/brake output inertia. (lb. ft.<sup>2</sup>)

N = Speed in revolutions per minute (RPM)

t = Time allowed for the engagement (sec)

## C-face Clutch/Power-on Brake Dynamic Torque Curves

### UM 50

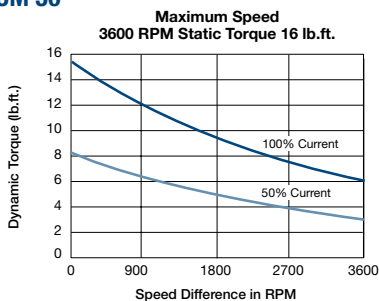

### UM 180

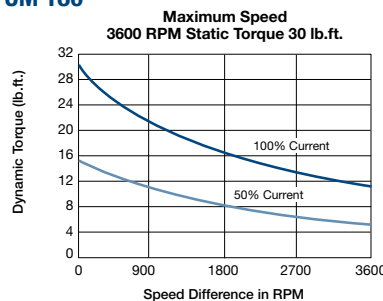

### UM 210

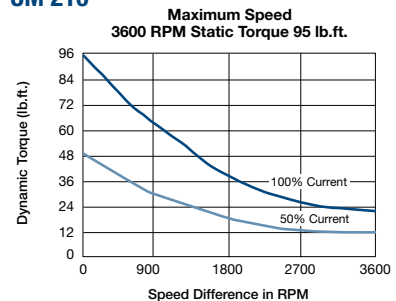

# UM-C Series UniModule – Ceramic Faced

## Selection/Ordering Information

### Specifications

UM Size	Shaft Dia	Static Torque (lb. ft.)	Horsepower	Maximum RPM	Voltage DC	NEMA Frame Size
UM50-C	5/8"	16	1/4-3/4	3600	6, 24 and 90	56C/48Y
UM180-C	7/8"	30	1-2	3600	6, 24 and 90	182C/143TC 184C/145TC
UM210-C	1-1/8"	95	3-5	3600	6, 24 and 90	213/182TC 215C/184TC

### 3. Select Accessories

Warner Electric UniModules can be fitted with several accessories to extend their capacity and ease of mounting.

#### a. Conduit Box

NEMA 4 and UL listed.

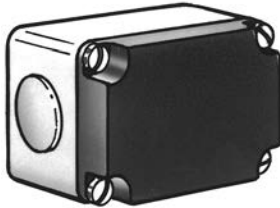

#### c. Fan Kit (1020 only)

Extends the thermal capacity of any size UM. Mounts between motor and UM, includes shaft fan, guard and hardware.



### 4. Select Control

Warner Electric manufactures clutch/brake controls to meet several system functions including:

- On/Off
- Torque adjust
- Overexcitation
- Position loop

Many requirements beyond function can impact control selection. See the Controls Section on page CTL-1 for complete information.

### b. Mounting Brackets

Two styles of mounting brackets are available for simplified installation. The base mount is used with the 2030 configuration. A motor mount is also available and provides sturdy support for the 1020 and a motor.

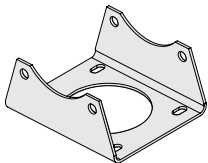

Base Mount

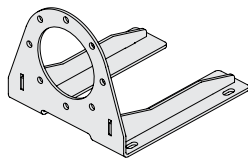

Motor Mount  
For 50, 100 & 180 sizes

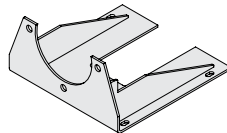

Motor Mount  
For 210 size

# UM-C Series UniModule – Ceramic Faced

## Selection/Ordering Information

### Part Numbers

Model No.	Voltage D.C.	Part No.
<b>1020 (Motor Clutch/Brake)</b>		
UM 50-1020-C	6	5370-273-271
UM 50-1020-C	24	5370-273-273
UM 50-1020-C	90	5370-273-274
UM 180-1020-C	6	5370-273-276
UM 180-1020-C	24	5370-273-278
UM 180-1020-C	90	5370-273-279
UM 210-1020-C	6	5371-273-035
UM 210-1020-C	24	5371-273-036
UM 210-1020-C	90	5371-273-037
<b>2030 (Input Clutch/Brake)</b>		
UM 50-2030-C	6	5370-273-281
UM 50-2030-C	24	5370-273-283
UM 50-2030-C	90	5370-273-284
UM 180-2030-C	6	5370-273-286
UM 180-2030-C	24	5370-273-288
UM 180-2030-C	90	5370-273-289
UM 210-2030-C	6	5371-273-039
UM 210-2030-C	24	5371-273-040
UM 210-2030-C	90	5371-273-041

### Accessories

Description	UM-C Size	Part Number
Conduit Box	All sizes	5370-101-042
Fan Kits 1020	50	5370-101-055
	180	5370-101-054
	210	5371-101-029
Base Mount Kits for 2030-C	50	5370-101-004
	180	5370-101-002
	210	5371-101-001
Motor Mount Kits for 1020-C	50	5370-101-078
	180	5370-101-079
	210	5371-101-012

### How to Order

#### Motor or Reducer Mounted

Simply combine the size number with the configuration of the required UniModule. Specify voltage. See chart for specific part numbers. Order optional conduit box if desired.

#### Example

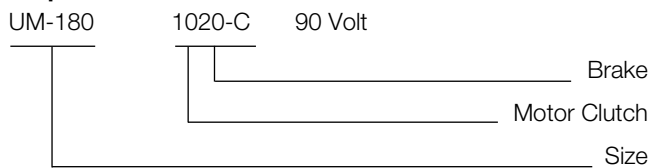

#### Base Mounted

Simply combine the size number with the configuration of the required UniModule. Specify voltage. See chart for specific part numbers. Order optional conduit box if desired.

#### Example

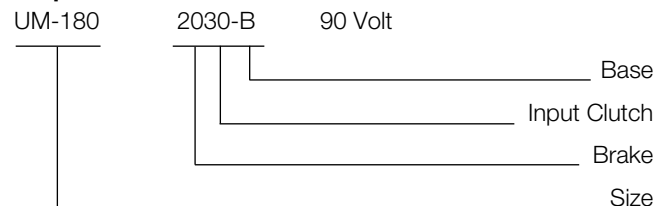

# UM-C Series UniModule – Ceramic Faced

## UM-1020-C Motor Clutch/Brake Combination

### SIZE 50/180

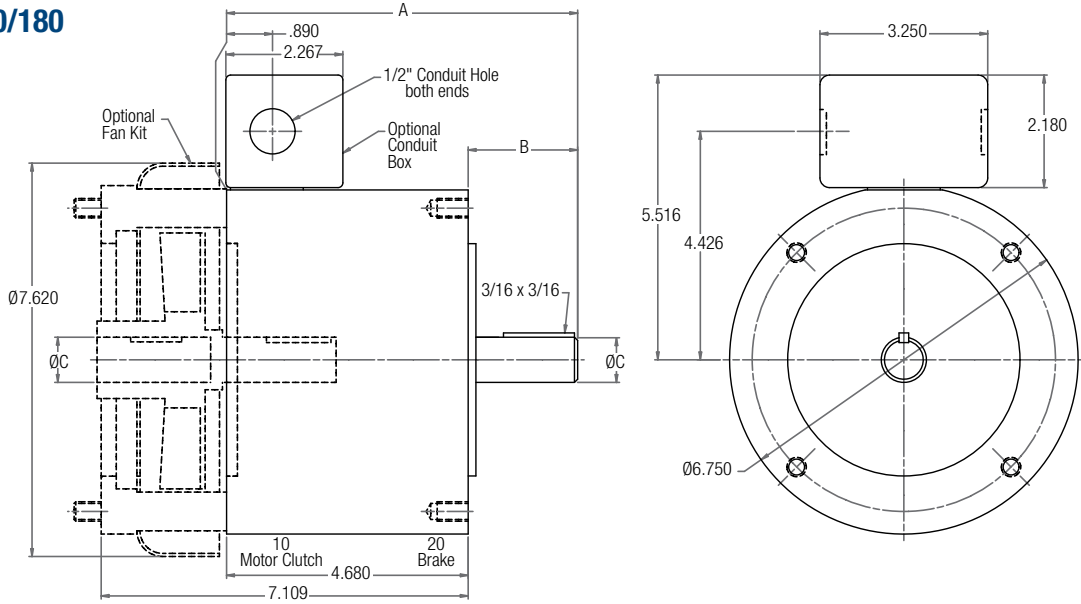

### SIZE 210

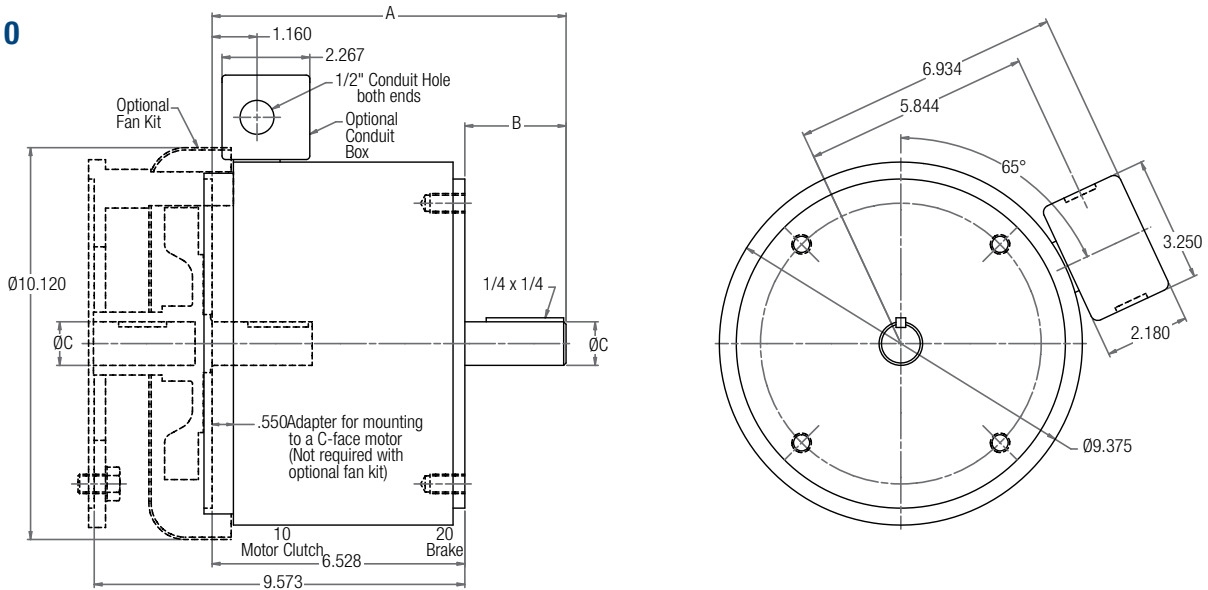

### Dimensions

Size	A	B	C
50	6.720	2.040	0.625
180	6.801	2.121	0.875
210	9.142	2.614	1.125

\*Dimension includes the .500 thick adapter. Required for C-face mounting to a motor.

### Specifications

For standard NEMA frame dimensions, see page G-3.

UniModule Size	Static Torque lb. ft.	Horsepower	Max. RPM	Voltage DC	NEMA Frame Size
UM50-C	16	1/4-3/4	3600	6, 24 and 90	56C/48Y
UM180-C	30	1-2	3600	6, 24 and 90	182C/143TC 184C/145TC
UM210-C	95	3-5	3600	6, 24 and 90	213/182TC 215C/184TC

# UM-C Series UniModule – Ceramic Faced

## UM-2030-C Brake/Input Clutch Combination

## UM-2030-C-B Brake/Input Clutch Combination–Base Mounted

### SIZE 50/180

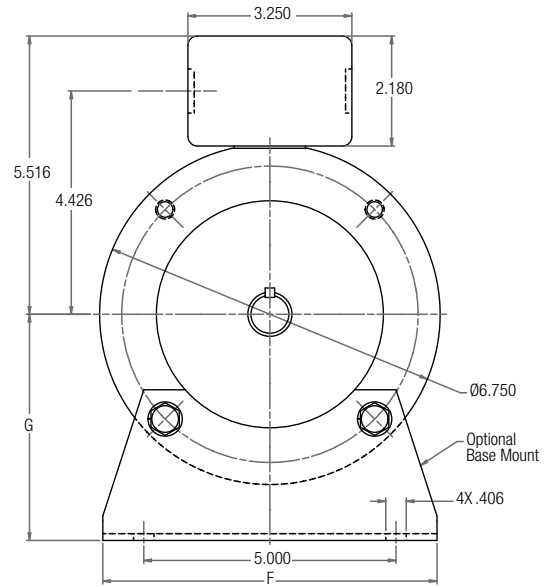
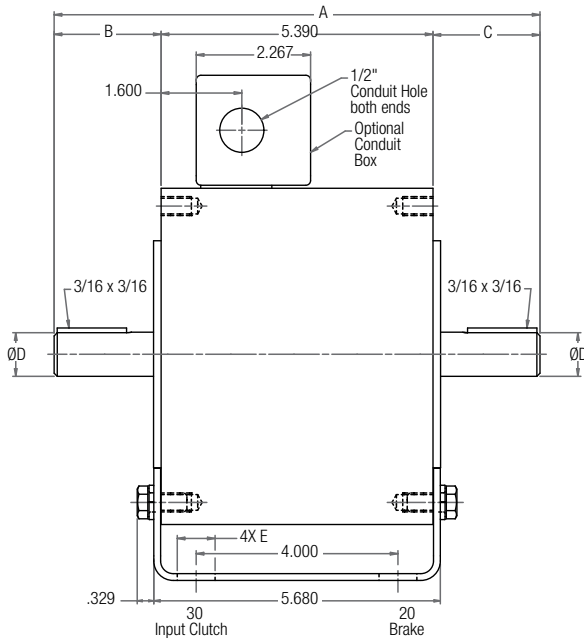

### SIZE 210

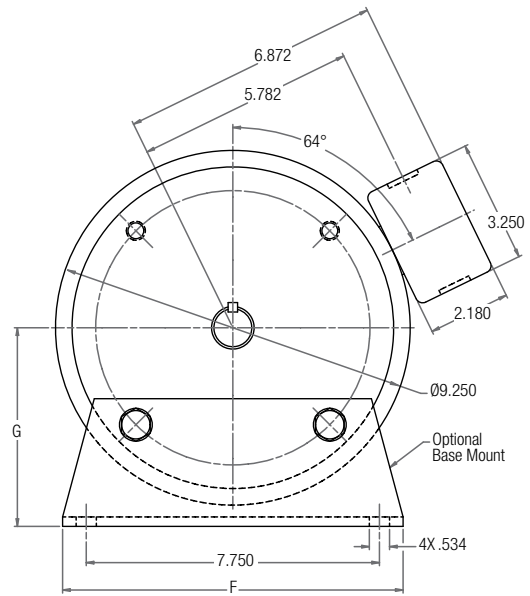
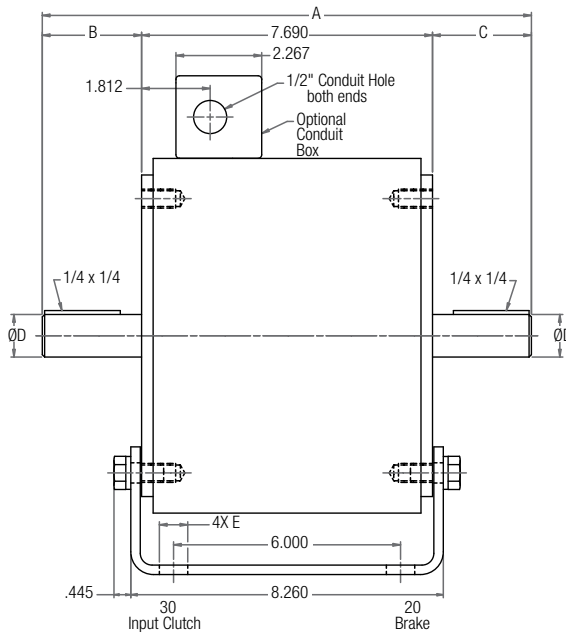

### Dimensions

Size	A	B	C	D	E	F	G
50	9.492	2.062	2.040	0.625	0.800	6.000	3.500
180	9.632	2.121	2.121	0.875	0.750	6.625	4.500
210	12.929	2.625	2.614	1.125	0.750	9.000	5.250

### Specifications

For standard NEMA frame dimensions, see page G-3.

UniModule Size	Static Torque (lb. ft.)	Horsepower	Max. RPM	Voltage DC	NEMA Frame Size
UM50-C	16	1/4-3/4	3600	6, 24 and 90	56C/48Y
UM180-C	30	1-2	3600	6, 24 and 90	182C/143TC 184C/145TC
UM210-C	95	3-5	3600	6, 24 and 90	213/182TC 215C/184TC