

Permanent Magnet Electrically Released Brakes

Permanent Magnet Brakes

Frequent cycling applications which regularly engage the brake to stop a moving load call for FB or ER models. Frequent cycling keeps working surfaces burnished and operating at top efficiency. The convenience of power off braking combines with stopping capability in the event of power failure to provide the ideal brake for many applications.

FB Series (Shaft Mounted)

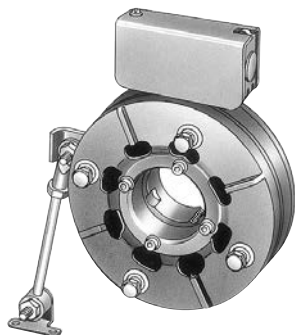

FB Series permanent magnet brakes are offered as off-the-shelf, pre-assembled packages in three sizes. Packaged products are easy to install.

ER Series (Flange Mounted)



ER Series permanent magnet brakes allow customers added flexibility and larger sizes. 825 and 1225 are available in both standard and heavy duty models.

Principle of Operation

Electrically Released Brakes automatically engage when the power goes off. Reliable permanent magnets provide a permanent holding force. Electrical power applied to the coil nullifies the attraction of the permanent magnet and the brake releases. No power is required to stop or hold a load.

Packaged Convenience for Power Off Applications

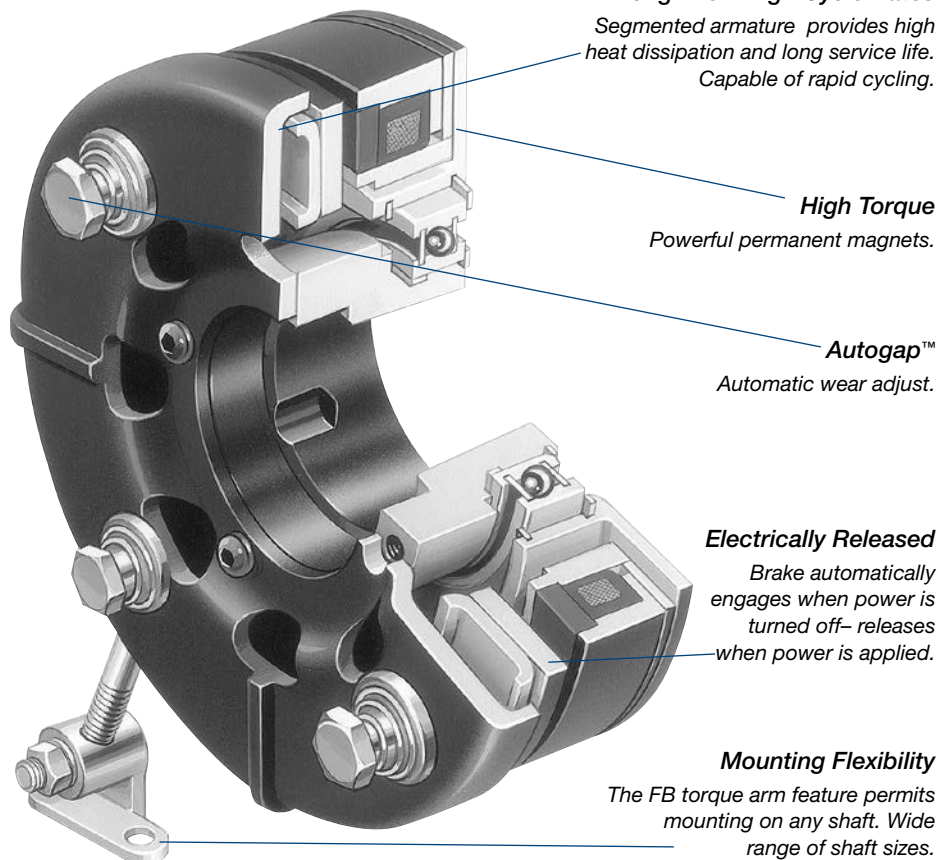

FB Magnetically Set, Electrically Released, Dynamic Engagement Brake

Packaged brake assembly complete with conduit box is ready to install.

This brake must be engaged while the shaft is in motion. Shaft speed should be 100 RPM or greater when the brake is engaged. This style brake offers quick and easy bearing mounting on the shaft, high cycle rate capability, and excellent life.

FB Brake on double shaft motor.

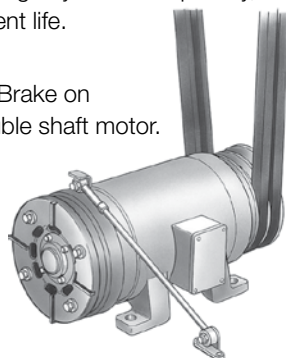

Features

- Designed for dynamic stopping operations
- Brake automatically engages when power is turned off
- High cycle rate capability
- Never needs adjustment – automatically compensates for wear
- Mounting flexibility
- Powerful permanent magnets
- Segmented armature design provides high heat dissipation and long service life.
- Complete controllability for soft stops.
- UL listed

FB Series Electrically Released Brakes

Selection/Ordering Information

Selection Procedure

FB (Shaft Mounted) Series brakes are available in three models to provide an optimum size to match your application requirements. Static torque capabilities range from 10.5 lb.ft. to 56 lb.ft.

1. Verify that the brake will be cycled frequently in normal operation.
2. Determine the horsepower and speed at the brake location.
3. The correct size Electrically Released Brake is shown at the intersection of the HP and shaft speed on the chart below.
4. Available bore sizes are listed in the bore data chart. When ordering, specify voltage and bore size.
5. Five motor adapters are also available for mounting Electrically Released Brakes on single shaft extension motors (see motor adapter bore size chart on page A-6). For double shaft extension motors, the adapter can be eliminated. Specify motor shaft size.

How to Order

1. Specify brake part number.
2. For FB-475 and FB-650, order bushing separately (see page A-9). FB-375 does not require a bushing.
3. For single shaft motor mounting, order adapter separately (Item 2 below). Specify the following bore size for the FB brake. This is the bore size required for mounting the electrically released brake on the end of the motor adapter.
 FB-375 5/8" bore
 FB-475 1 bore
 FB-650 1-3/8" bore
4. See the Controls Section for controls. FB Series brakes require a control with a potentiometer to vary brake channel output.
 CBC-300 or 500/550 are recommended.

Horsepower vs. Shaft Speed*

HP	SHAFT SPEED AT BRAKE (IN RPM)*																			
	100	200	300	400	500	600	700	800	900	1000	1100	1200	1500	1800	2000	2400	3000	3600	4000	4500
1/12																				
1/8																				
1/6																				
1/4																				
1/3																				
1/2																				
3/4																				
1																				
1-1/2																				
2																				
3																				
5																				
7-1/2																				
10																				
15																				

* For applications which require stopping below 100 RPM, consult factory.

Specifications

Model	Voltage DC	Static Torque (lb.ft.)	Max. RPM	Total Weight (lbs.)
FB-375	24V	10.5	5000	4.5
	90V			
FB-475	24V	21	4500	6.3
	90V			
FB-650	24V	56	3600	13.2
	90V			

Electrically Released Brake Assemblies

Unit Size	Bore	Voltage DC	Part Number
FB-375	1/2"	24	5390-170-024
FB-375	1/2"	90	5390-170-021
FB-375	5/8"	24	5390-170-023
FB-375	5/8"	90	5390-170-022
FB-475	—	24	5391-170-012
FB-475	—	90	5391-170-009
FB-650	—	24	5392-170-010
FB-650	—	90	5392-170-007

Typical Application

Storage Elevator

These brakes will stop as well as keep a load in position until they are electrically released. They are also used as emergency stopping devices.

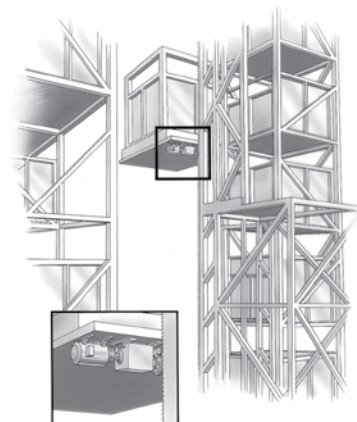

Permanent Magnet Electrically Released Brakes

Motor and Shaft Adapters

Motor Adapter Bore Sizes

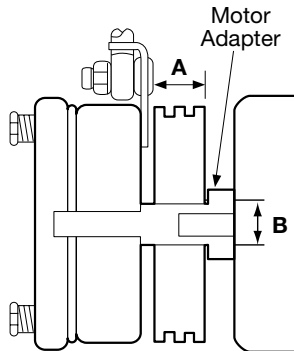

Model Size	Motor Shaft Size	A Usable Length	B Dia.	When using an adapter order the following	
				Adapter	Dodge Bushing
375	.625	2.000	.875	5380-101-005	*None
	.875	2.250	1.250	5380-101-004	*None
475	1.125	2.750	1.625	5381-101-003	#1008 1"
	1.375	3.000	2.000	5382-101-003	#1310 1.375"
650	1.625	3.625	2.250	5382-101-002	#1310 1.375"

*Order FB-375 with 5/8" bore.

FB Shaft Adapter

Shown below are dimensions and specifications for the optional shaft adapter available for mounting FB Series brakes on a motor. A standard sheave, pulley, or sprocket, with either a tapered bushing or straight bore, can be installed on the shaft adapter. The brake is mounted on the end of the shaft adapter and the complete assembly fits onto the motor shaft, secured with setscrews. Fitting the belts or chain and torque arm completes the installation.

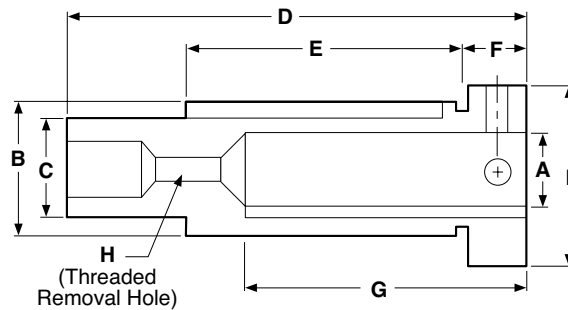

Model	A	Kwy.	B	Kwy.	Key Part No.	C	Kwy.	Key Part No.	Dodge Bushing Size	D	E	F	G	H	I
FB-375	5/8	3/16 x 3/32	7/8	3/16 x 3/32	590-0016	5/8	3/16 x 3/32	590-0043	None	4.391 4.359	2	.391 .359	2	1/4-20 UNC	1.125
FB-375	7/8	3/16 x 3/32	1-1/4	1/4 x 1/8	590-0022	5/8	3/16 x 3/32	590-0043	None	4.578 4.742	2-1/4	.516 .484	2-1/4	1/4-20 UNC	1.500
FB-475	1-1/8	1/4 x 1/8	1-5/8	3/8 x 3/16	590-0041	1	1/4 x 1/8	—	#1008 1"	4.516 4.484	2-3/4	.641 .609	2-3/4	1/2-13 UNC	1.750
FB-650	1-3/8	5/16 x 5/32	2	1/2 x 1/4	590-0042	1-3/8	5/16 x 5/32	590-0044	#1310 1-3/8"	5.547 5.515	3-3/8	.641 .609	3-3/8	1/2-13 UNC	2.125
FB-650	1-5/8	3/8 x 3/16	2-1/4	1/2 x 1/4	590-0042	1-3/8	5/16 x 5/32	590-0044	#1310 1-3/8"	6.172 6.140	4	.641 .609	4	1/2-13 UNC	2.375

All dimensions are nominal unless otherwise noted.

FB Series Electrically Released Brakes

FB-375, FB-475, FB-650

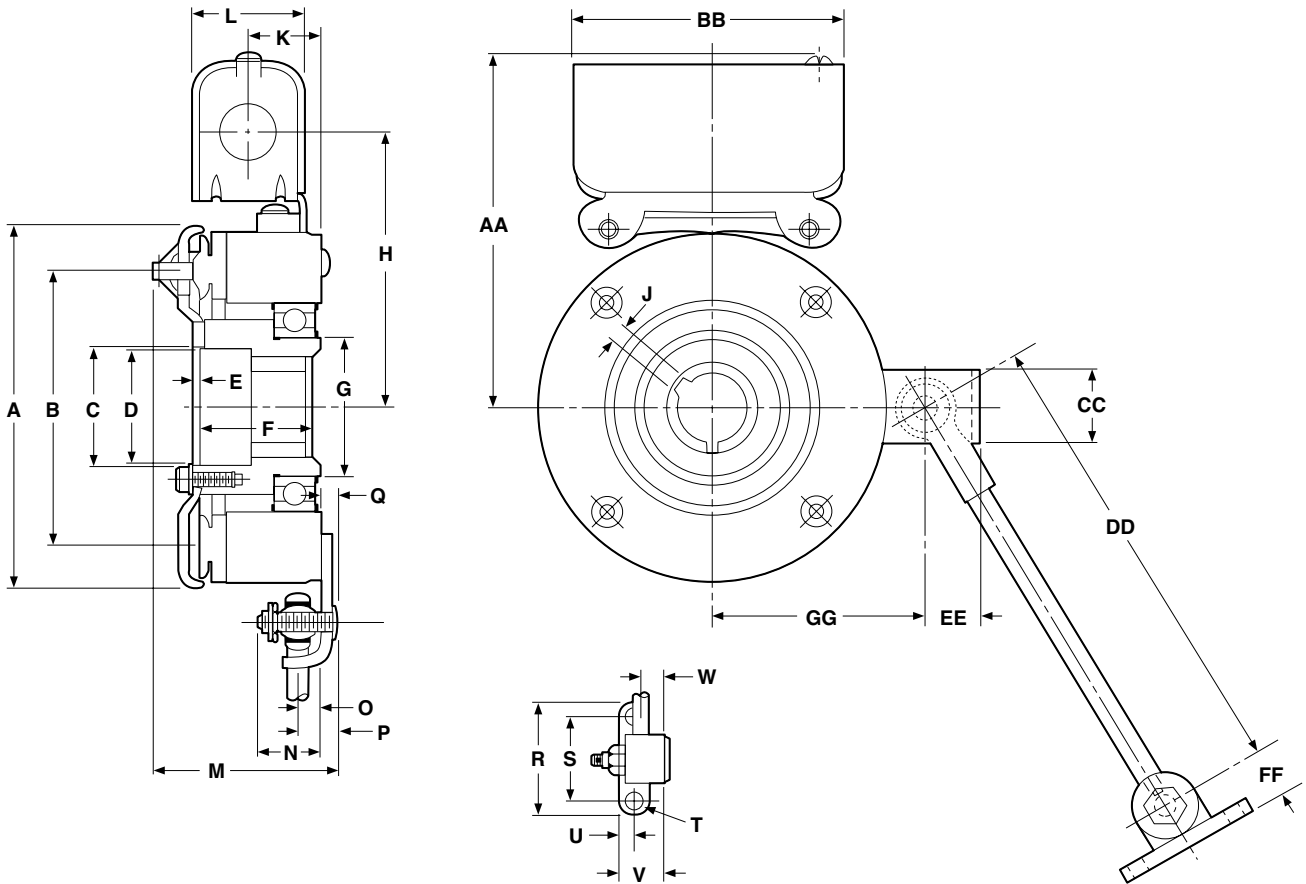

Dimensions

All dimensions are nominal, unless otherwise noted.

Size	A	B	C	D	E	F	G	H	J	K	L	M	N	O	P
375	4.078	3.125	.7505	—	.031	1.906	1.375	3.359	.187	1.281	1.546	2.716	.843	.281	.531
475	5.171	4.000	1.663	1.593	—	1.875	1.781	3.875	—	1.218	1.546	3.390	1.093	.312	.531
650	6.578	5.125	2.343	2.281	—	2.250	2.562	4.800	—	1.550	1.546	3.765	1.031	.343	.640

Size	Q	R	S	T	U	V	W	AA	BB	CC	DD	EE	FF	GG
375	—	2.000	1.500	.270	.270 .260	.781	.359	4.468	3.750	1.000	8.000	.666	.635	2.578
475	.281	2.000	1.500	.270	.270 .260	.781	.390	4.984	3.750	1.000	10.000	.697	.635	3.094
650	.359	2.000	1.500	.270	.270 .260	.781	.437	5.843	3.750	1.125	11.000	.843	.635	4.062

Bore Data (Key furnished)

Size	Bore Dia.	Keyway
FB-375	.626/.625	3/16 x 3/32
	.501/.500	1/8 x 1/16
FB-475	.500 - .562	1/8 x 1/16
Dodge #1008	.625 - .875	3/16 x 3/32
	.937 - 1.000	1/4 x 1/8
FB-650	.500 - .562	1/8 x 1/16
Dodge #1310	.625 - .875	3/16 x 3/32
	.937 - 1.250	1/4 x 1/8
	1.312 - 1.375	5/16 x 5/32

Note: FB-375 has a straight bore. Bushing not required.
Bushings also available in metric bores. See page A-9.